

YLAA

Air-cooled scroll compressor chiller

Cooling capacities from 195 kW to 528 kW



Features

The **YORK YLAA TEMPO** air-cooled chiller is an environmental leader.

Utilising scroll type compressors and microchannel condenser coil technology the **YLAA** delivers premium efficiency for all air conditioning applications.

YLAA chillers are a self-contained cooling solution that is light-weight and compact for convenient installation on the ground or on building rooftops.

Options/Accessories

- Variable speed EC fans
- Hydrokits with fixed or variable speed pump (single or dual)
- Soft start
- Power factor correction capacitors
- Low ambient kit
- BMS interfacing options
- Dual pressure relief valves
- Victaulic coupling
- Flow switch
- Heat recovery option
- Enclosure options
- Sound attenuation options
- Anti-vibration mounts options
- Epoxy post-coated dipped microchannel coils

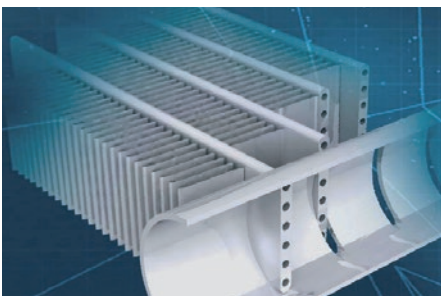

The TEMPO delivers energy efficiency levels that surpasses Ecodesign Tier 2 requirements. Aluminium microchannel condenser coil technology is one reason for this premium efficiencies.

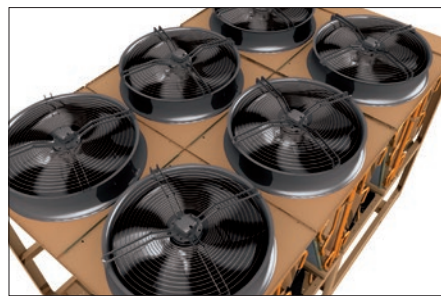

Ultra quiet operation and outstanding part load efficiency can be obtained through variable speed EC fans and a compressor acoustic blankets.

A single point power connection and optional, factory packaged water pumps, water filter and flow switch provide fast and easy installation.

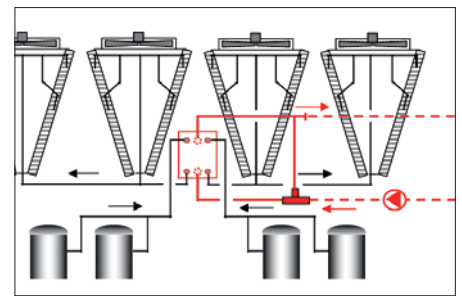

An optional heat recovery feature can be added to provide hot water to 60°C; which is useful for facility heating or hot water preheating.

Air-cooled scroll compressor chiller

YLAA 0195 to 0517



Nominal capacity

YLAA	0195*	0221	0262	0286	0301	0350	0392	0442	0457	0517
Cooling capacity (kW)	195	211	246	274	299	347	376	434	469	528
EER	3.17	3.40	3.24	2.79	3.17	3.07	3.09	3.07	3.09	3.10
SEER	4.28	4.65	4.40	4.14	4.44	4.36	4.46	4.58	4.70	4.57
$\eta_{s,c}$	168	183	173	162	174	171	175	180	185	180
Sound power level dB(A)	87	83	83	84	85	86	86	87	87	87

Net values at Eurovent nominal conditions:

Cooling capacities in kW given for 7°C water leaving temperature Δt 5°C and 35°C ambient temperature.

Ecodesign figures are calculated following fixed water and variable outlet approach (FW/VO). For other Ecodesign calculations, please contact your JCI representative.

(* All models with R454B refrigerant using EC fans (except size 0195) and Compressor Sound Blankets.

The above data is based on Johnson Controls' selection software YORKworks 20.05b. Please refer to the latest version of the software for specific projects.

Technical data

YLAA			0195	0221	0262	0286	0301	0350	0392	0442	0457	0517
Dimensions	Length	mm	2911				3690				4807	
	Width	mm	2242								2254	
	Height	mm					2508					
Operating weight kg			1706	1721	1852	1853	2170	2339	2508	3343	3481	3615

YLAA Pump Kit

- Fixed or VSD water pump
- Single or Dual water pump
- Two option levels - basic and full featured - for maximum flexibility
- More impeller size options for better match to customer requirements
- New, smaller pump motors suitable for primary-secondary systems

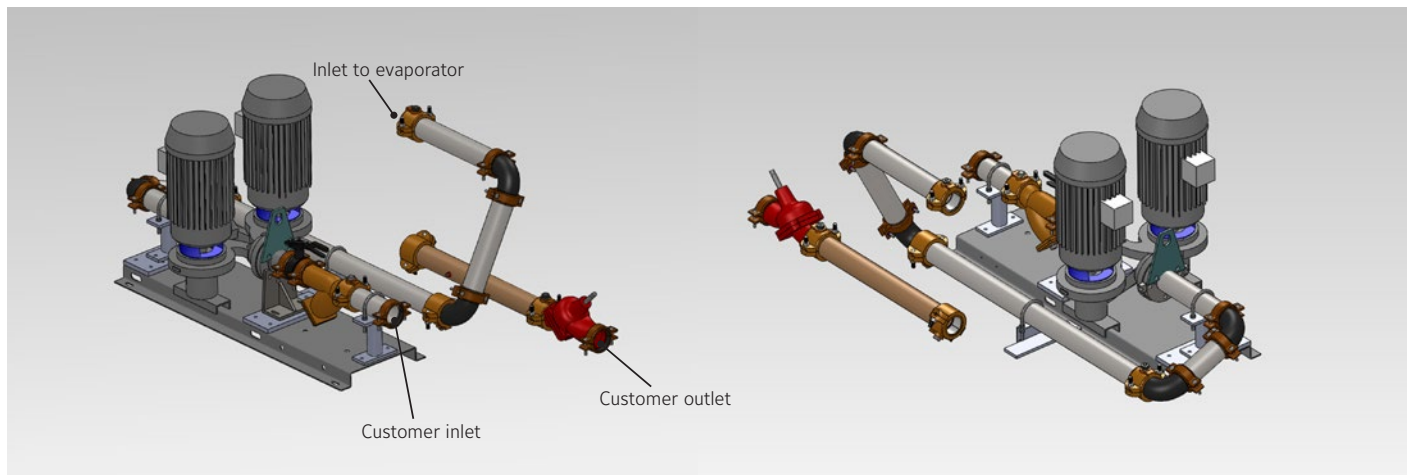

Manufacturer reserves the rights to change specifications without prior notice.

Dimensions and hydraulic connections

YLAA 0195, 0221 and 0262

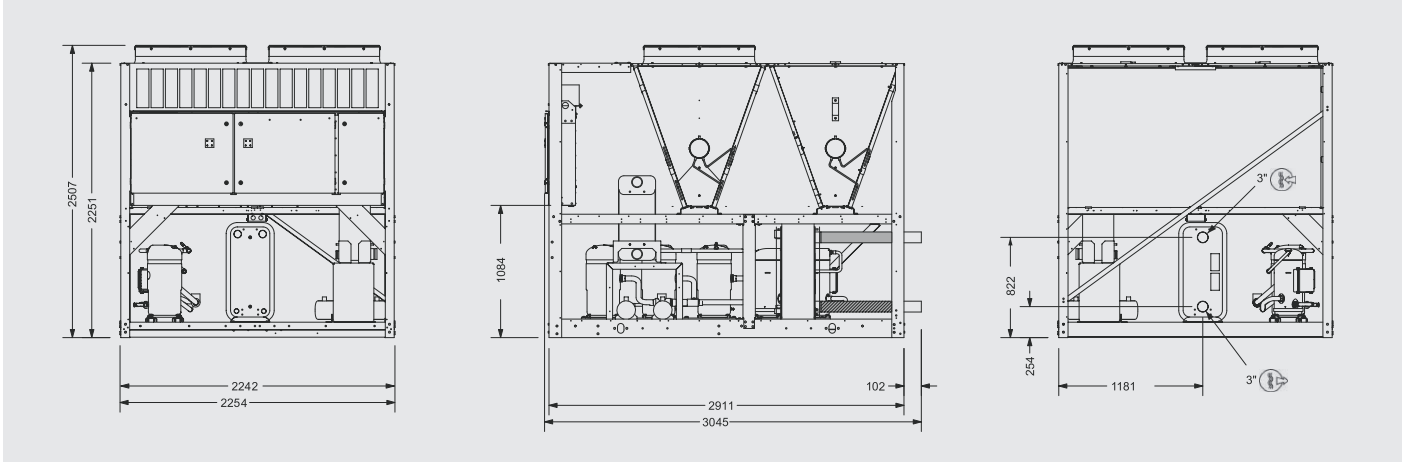

All dimensions in mm. Drawings not in scale.

YLAA 0301 and 0392

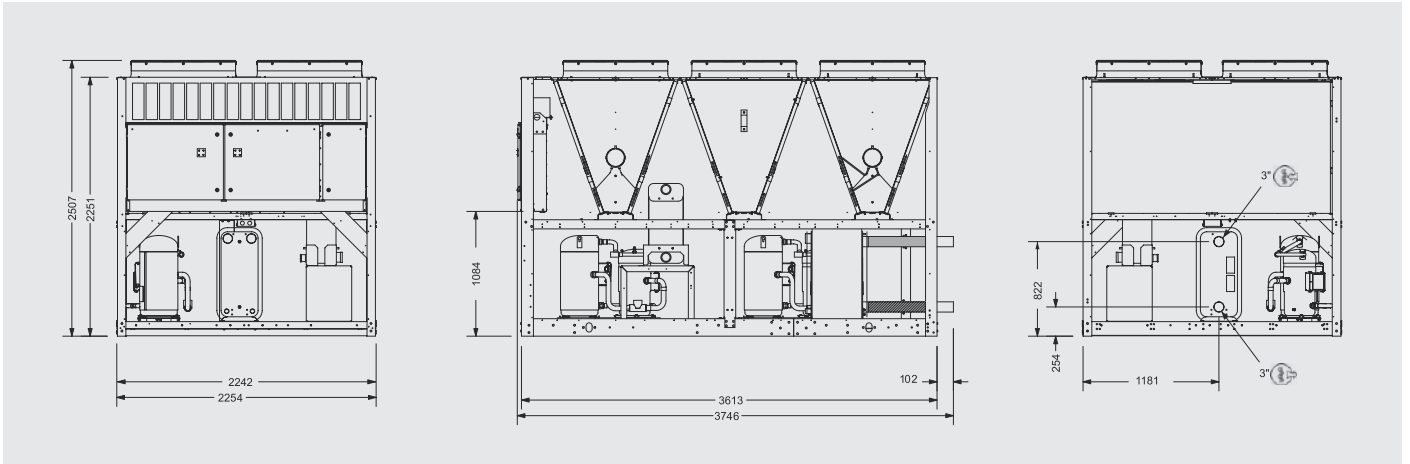

All dimensions in mm. Drawings not in scale.

YLAA 0195 to 0517



YLAA 0442

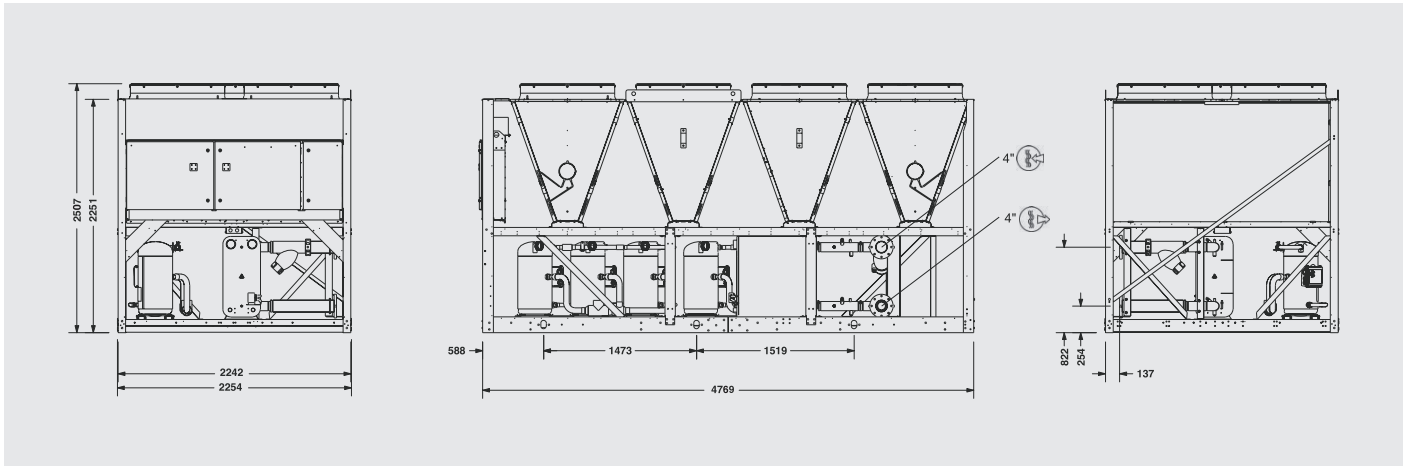

All dimensions in mm. Drawings not in scale.

YLAA 0457 and 0517

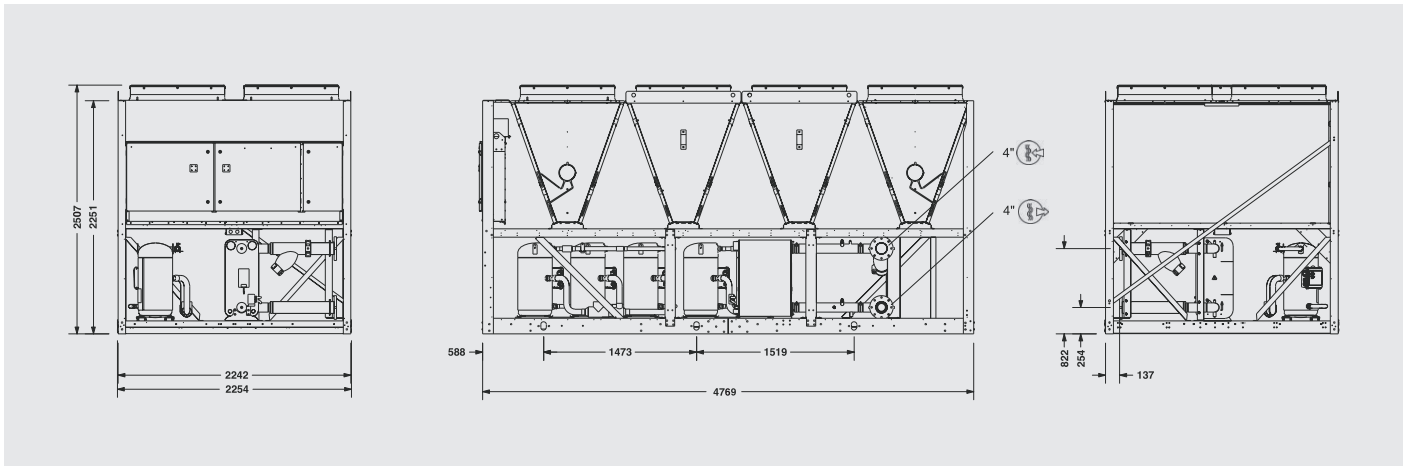

All dimensions in mm. Drawings not in scale.